

INSTRUCTION MANUAL
MODEL: KT-9900E

Speakerphone with caller ID, message waiting & incoming call indication.



Before operating this instrument please read the instruction manual carefully. Keep the manual for future reference.

INTRODUCTION

Thank you for purchasing a Kingtel product which adopts excellent workmanship and exceptional reliability.

Your telephone is designed to give you flexibility in use and high quality performance. To get the most from your new telephone, we suggest that you take a few minutes to read through this instruction manual to familiarize yourself with all the features of the product.

The product is guaranteed for 12 months from the date of purchase shown on your sales receipt. The guarantee does not cover damage caused by misuse or negligence or by excessive voltage. For example, faults on the telephone line or lightning.

IMPORTANT SAFETY INSTRUCTIONS

When operating your telephone instrument, basic safety precautions should always be followed to reduce the risk of fire, electric shock or injury to Persons.

1. Follow all warnings and instructions.
2. Unplug this product from the wall outlet before cleaning. Do not use Liquid cleaning materials nor aerosol. Use a damp cloth for cleaning.
3. Do not use this product near water.(i.e. Near a bathtub,kitchen sink,washing machine,in a wet basement, or near a swimming pool). Avoid spilling liquid on the product.
4. Do not place this product on an unstable cart,stand, or table.The product may drop, causing serious damage to the product or injury to persons.
5. Do not allow any object to rest on the telephone cord. Stow the line cord in a way that it can not cause injury to persons or damage to the line cord.
6. Never push foreign objects of any kind into the product as it may touch dangerous voltage points or short out parts that could result in fire or electrical shock.
7. To reduce the risk of electric shock, do not disassemble this product.Submit it to a qualified service authority if service or repair work is required.Opening or removal of the cover may expose you to dangerous voltage points. Incorrect reassembly can cause electric shock when operating the instrument.
8. Adjust only the controls that are covered by this instruction manual. Improper adjustment of controls may result in damage that could require extensive work by a qualified technician.
9. Refer servicing to a qualified technician if the following should occur:

- When the phone line or plug is damaged or dryed.
 - If liquid has been spilled into the product.
 - If the product has been exposed to rain or water.
 - If the product does not operate normally by following the operating instructions.
 - If the product has been dropped or the cabinet has been damaged.
 - If the product exhibits a distinct change in performance.
10. Avoid using a telephone during an electrical storm. There may be a risk of Electric shock from lightning.
 11. Do not use the telephone in the vicinity of a gas leak.
 12. The handset receiver may retain dangerous materials such as metallic pins And staples because the receiver is magnetic.
 13. Do not overload wall outlets and extension cords as this can result in electric shock or fire.
 14. Connect all leads / cords to the intended sockets.

PRODUCT FEATURES

1. 5 meter range, high-quality speakerphone
2. Message waiting & incoming call indication
3. 76 caller ID memories
4. Last 10 dialed numbers review and redial
5. Hold with mute/music&extension release
6. Automatic call timer
7. Flash time adjustable:100ms,200ms,300ms,400ms,600ms,900ms
8. On hook pre-dial
9. Adjustable handset volume
10. Adjustable speaker volume
11. Adjustable ringer volume
12. 16 digit LCD display with adjustable contrast
13. Unique stand for easy operation and better LCD viewing angle

LOCATION AND FUNCTION OF CONTROLS

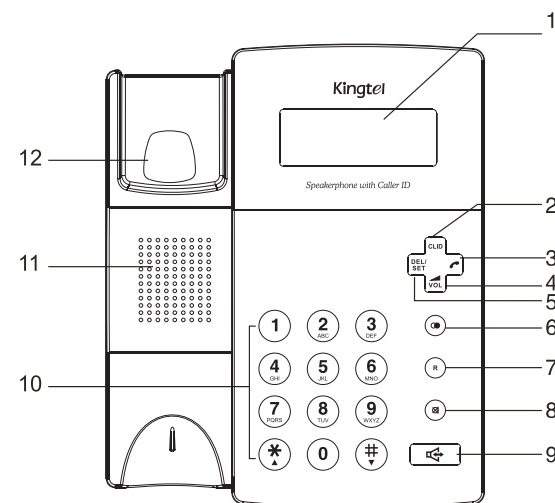

1. LCD display.....Display phone number,date,time and other information.
2. * CLID #Review received and missed calls.
- 3.Call Back.....Press to dial a stored number when viewing Caller ID or phonebook entry.
- 4.Vol ▲a. In off-hook status,press to adjust handset volume
b. In speaker phone status,press to adjust speaker volume.
c. In on-hook status, press and hold to adjust ringer volume.
- 5.Del/set.....a. In on-hook status,press and hold 3 seconds to enter into menu set up.
b.Press and hold for 3 seconds to delete caller ID numbers or outgoing numbers.
- 6.Redial.....a. In on-hook status,press repeatedly to review outgoing numbers.
b. Pick up handset and press to dial the last dialed number.
- 7.Flash.....For use behind a PABX for intercom/transfer.

- 8.Mute.....Press & hold to prevent the other party from hearing your conversation.
- 9.Speakerphone/ In use/message waiting indication.....
 - a. Press to initiate a new call or end a call
 - b. Light up when the unit is in use,flashes when there is a new call,flashes when on hold.
 - c. In speakerphone mode press to dial the last dialed number.
- 10.Dialing key(0-9).....Dial numbers and extensions.
- 11.Speaker.....Voice/ring tone is transmitted from the speaker.
- 12.Hook on/ off switch.....Press to end a call.

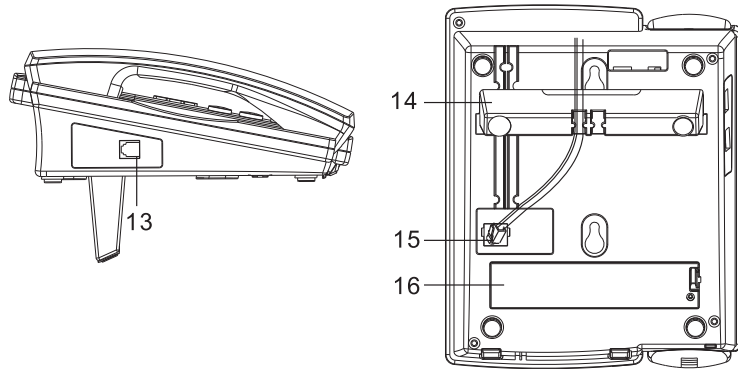

- 13.Handset Jack
- 14.Stand
- 15.Line cord jack.....Connects telephone to wall jack.
- 16.Battery compartment

INSTALLATION

- 1.Connect one end of the curly cord to the handset jack and connect the other end to the jack on the base of the telephone (see page 4 /No. 13)
- 2.Plug one end of the phone line into the line jack on the telephone base and connect the other end to the wall jack (see page 4 /No. 15).

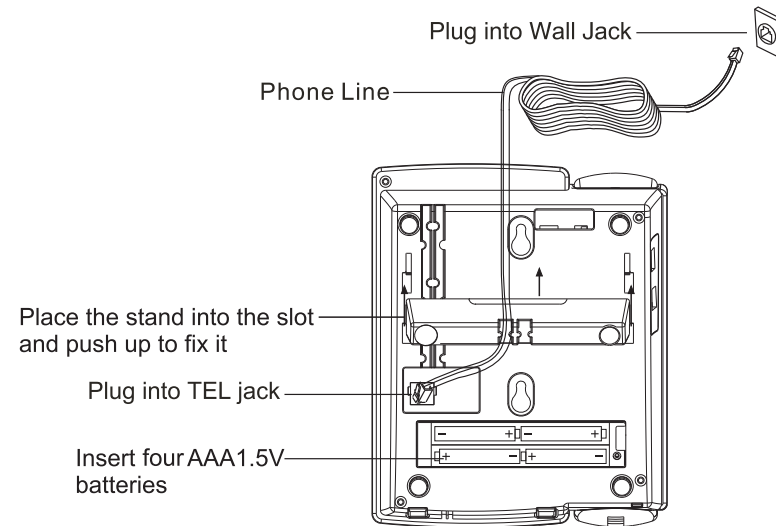

FUNCTION SETUP

1. Set year,date and time

Press **DEL/SET** for 3 seconds,the LCD display "set 1 date",press **DEL/SET** again to confirm.The digits of the year flashes.Press **▲ or ▼** to select the year, press **DEL/SET** to confirm.The digits of the month will flash,press **▲ or ▼** to select the month and press **DEL/SET** to confirm.Repeat the procedure to set the day/date and time.
2. Set local code

After setting year,date and time,press **DEL/SET** to advance to the local area code setting. The LCD displays "set 2 code",press **DEL/SET** again,press **▲ or ▼** to enter the first digit of the local area code and press **DEL/SET** once again to move to the next digit of the area code. Repeat the procedure until the area code is entered and press **DEL/SET** to confirm.Repeat the procedure to set other area codes. Once an area code has been set and a

call is received with the same area code, as the set area code only the telephone number will display on the LCD without the area code. Example: area code 248 is set in the phone memory a call is received with number 248-1234567, only 1234567 will display on the LCD.

3. Set prefix code

After setting the local code, press **DEL/SET** to advance to prefix code setting. The LCD displays "set 3 pcode", press **DEL/SET** to confirm, the first digit of three will flash, press *** or #** to select digits and press **DEL/SET** to advance to the next digit of the prefix code.

Use the same method to continue setting each digit.

4. Set the contrast

After setting the prefix code, LCD displays "set 4 LCD 1" press **DEL/SET** to confirm, press *** or #** to set the contrast(1-5), then press **DEL/SET** to confirm.

5. Set the ring melodies

After setting the contrast of LCD, the LCD display "set 5 ring", press **DEL/SET** to confirm. Press *** or #** to select a melody(1-16) and press **DEL/SET** to confirm.

6. Set the ring volume

After setting the ring melodies, the LCD displays "set 6 r-vol", press **DEL/SET** to confirm, then press *** or #** to select ring volume(1-8) and press **DEL/SET** to confirm.

7. Set flash time

After setting the ring volume, the LCD displays "set 7 flash", press **DEL/SET** to confirm, then press *** or #** to select the flash time(100ms, 200ms, 300ms, 400ms, 600ms, 900ms) and press **DEL/SET** to confirm.

8. Set pause time

After setting the flash time, the LCD displays "set 8 pause", press **DEL/SET** to confirm, then press *** or #** to select pause time(1.2s/2.4s/3.6s). Press **DEL/SET** to confirm.

9. Set DTMF or Pulse mode

After setting the pause time, the LCD displays "set 9 T-P", press **DEL/SET** to confirm, then press *** or #** to select the mode(DTMF or Pulse) and press **DEL/SET** to confirm and complete the whole setting.

Note. Pause

When dialing, press the REDIAL button to insert a 3.6s pause time between digits. This function is used behind a PABX. Insert the PAUSE between the PABX access digit (usually 0 or 9) and the number to be dialed. Use this function when you want to redial a number or when you store a number in memory.

OPERATION

1. Place a call:

Pick up the handset or press **↔**, after receiving dial tone dial the desired number. When the other party answers the phone call the call duration timer will display on the LCD after 5 seconds.

2. Answer a call:

Pick up the handset or press **↔** to answer a call.

3. End a call:

Hang up the handset or press **↔** to end the call.

4. Switch talk mode from handset to speakerphone:

Press **↔** and then hang up the handset to talk through the speakerphone.

5. Switch talk mode from speakerphone to handset:

Pick up the handset and the talk mode will switch to the handset automatically.

6. Redial:

a. In on-hook status, press **REDIAL** repeatedly to review the last 10 dialed numbers, display the desired number on the LCD and press **↔** or pick up the handset to dial out automatically.

b. In off-hook status, press **REDIAL** to dial the last dialed number.

7. Caller ID review:

In on-hook status, press *** or #** to review the last 76 caller ID memories.

8. Delete caller ID:

a. Whilst reviewing incoming call numbers, press *** or #** and select the number you wish to delete, press **DEL/SET** once quickly to delete a single number.

b. When reviewing incoming call numbers, press **DEL/SET** & hold for 3 seconds to delete all numbers.

9. Volume control:

a. In speakerphone mode, press **VOL** to adjust the speakerphone volume (0-7).

b. In handset mode, press **VOL** to adjust the handset volume (1-4).

c. In on-hook mode, press and hold **VOL** for 3 seconds, then press **VOL** to adjust the ring volume(0-7).

10. Flash:

This function is mainly for PBX systems or it only works while call waiting service is provided by your local communications company.

a. Press **FLASH** to transfer the call to another extension if the phone is connected to a PBX system.

b. Press **FLASH** for "call waiting" service provided by the service provider.

11.Pre-dial:

In on-hook status,dial the phone number and then pick up the handset or press , the number will be dialed out automatically.

12.Mute:

Press and hold the **[MUTE]** key to mute the telephone's microphone. The other party will not be able to hear you but you will still be able to hear their conversation. To restore both way conversation, release the mute button.

TROUBLE SHOOTING GUIDE

SYMPTOM	CAUSE AND REMEDY
NO DIAL TONE/PHONE IS DEAD	Check the hook switch and make sure it pops-up. Check that the line cord from the wall jack is plugged in properly. Check that all connectors are firmly inserted in the intended sockets.
RINGER VOLUME TOO LOW	Check the ringer volume setting. Increase the ringer volume (see function setup Page 6).
DIAL TONE BUT CAN'T DIAL OUT	Check that PULSE / TONE is set correctly according to the telephone exchange or PABX requirement.
NO CALLER IDENTIFICATION IS DISPLAYED	For caller identification to function you must subscribe to CLID service. Contact your service provider.
PHONE DOES NOT RING	Check the phone line cord. Could have too many phones on one line (the total REN of all phones should not be more than the maximum for your area, usually 5)

LAST NUMBER REDIAL AND/OR SPEED DIAL NOT WORKING ON A PABX	When you first make a call try pressing the Pause Button for a pause between the outside line access digit (eg: 9 or 0) and the telephone number, you should later be able to redial the number. If your PABX requires you to wait for a second dial tone before dialing the telephone number, press the Pause Button for a pause between the access digit and number.
LCD IS DIM	Adjust the LCD contrast (See Page 6, "set the contrast")
CAN'T TRANSFER A CALL TO ANOTHER PABX EXTENSION	Check that the flash time is set correctly. Flash time should be set to 100ms to comply to RSA Specification. (See Page 6, "set flash time")